

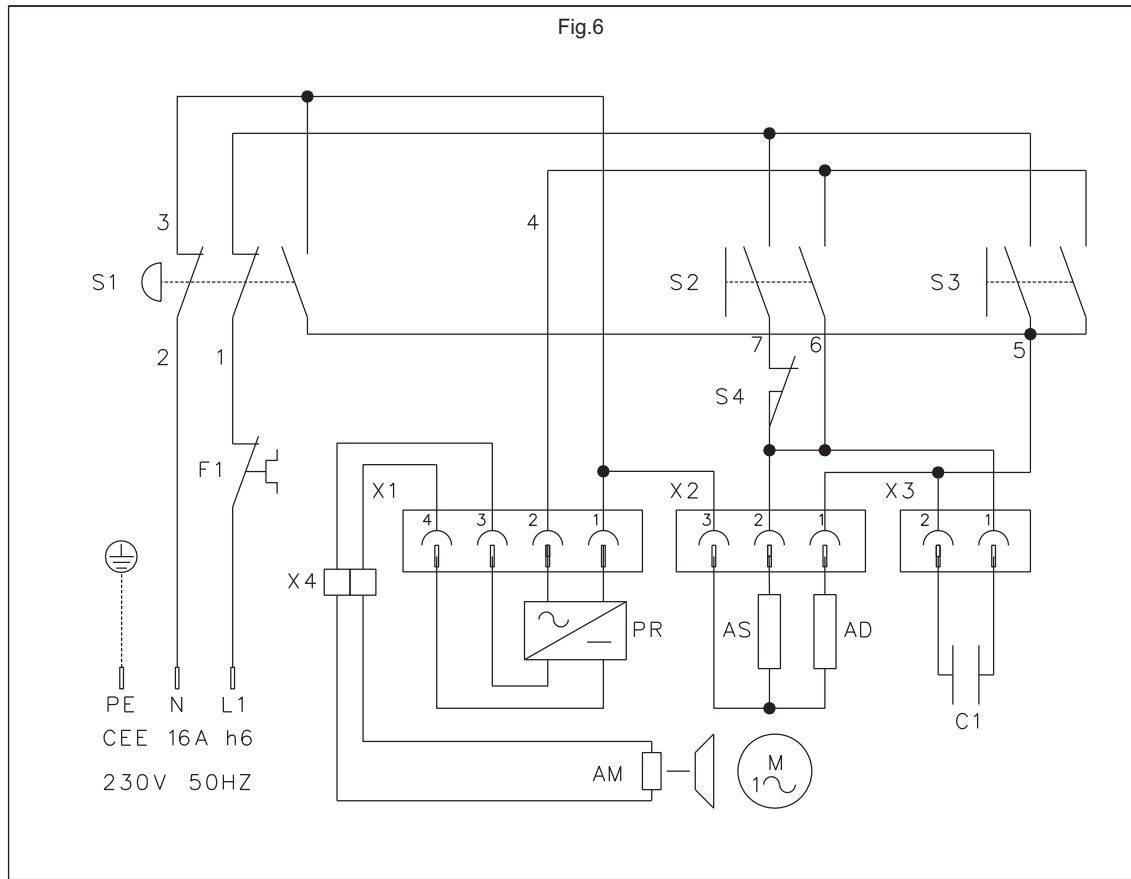

**SCHEMA ELETTRICO - SHEMA ELECTRIQUE - WIRING DIAGRAM - SCHALTAPLAN - ESQUEMA ELECTRICO**



**QUADRO COMANDO (Fig.6)**

- PE CONDOTTORE DI PROTEZIONE
- L1 CONDOTTORE DI LINEA FASE
- N CONDOTTORE DI LINEA NEUTRO
- S1 PULSANTE EMERGENZA
- S2 PULSANTE SALITA
- S3 PULSANTE DISCESA
- S4 FINECORSA SALITA
- F1 INTERRUTTORE TERMICO
- X1 CONNETTORE ALIMENTATORE
- X2 CONNETTORE MOTORE
- X3 CONNETTORE CONDENSATORE
- X4 MORSETTIERA FRENO
- C1 CONDENSATORE
- AS AVVOLGIMENTO MOTORE SALITA
- AD AVVOLGIMENTO MOTORE DISCESA
- AM AVVOLGIMENTO MAGNETE FRENO

**CONTROL PANEL (Fig.6)**

- PE PROTECTION WIRE
- L1 PHASE WIRE
- N NEUTRAL WIRE
- S1 EMERGENCY BUTTON
- S2 UPSTROKE BUTTON
- S3 DOWNSTROKE BUTTON
- S4 UPSTROKE LIMIT SWITCH
- F1 MAGNETOTHERMIC SWITCH
- X1 MAGNET POWERING CONNECTOR
- X2 MOTOR CONNECTOR
- X3 CAPACITOR CONNECTOR
- X4 MAGNET TERMINAL
- C1 CAPACITOR
- AS MOTOR WINDING UPSTROKE
- AD MOTOR WINDING DOWNSTROKE
- AM BRAKE MAGNET WINDING

**CUADRO DE MANDO (Fig.6)**

- PE CONDUCTOR DE PROTECCIÓN
- L1 CONDUCTOR DE LÍNEA FASE
- N CONDUCTOR DE LÍNEA NEUTRO
- S1 BOTÓN DE EMERGENCIA
- S2 BOTÓN DE SUBIDA
- S3 BOTÓN DE BAJADA
- S4 FINAL DE CARRERA SUBIDA
- F1 INTERRUPTOR TÉRMICO
- X1 CONECTOR DEL ALIMENTADOR MAGNETO
- X2 CONECTOR DEL MOTOR
- X3 CONECTOR CONDENSADOR
- X4 BORNES FRENO
- C1 CONDENSADOR
- AS BOBINADO MOTOR SUBIDA
- AD BOBINADO MOTOR BAJADA
- AM BOBINADO MAGNETO DEL FRENO

**PANNEL DU COMMANDE (Fig.6)**

- PE CONDUCTEUR DE PROTECTION
- L1 CONDUCTEUR DE LIGNE PHASE
- N CONDUCTEUR DE LIGNE NEUTRE
- S1 BOUTON-POUSSOIR D'URGENSE
- S2 BOUTON-POUSSOIR MONTEE
- S3 BOUTON-POUSSOIR DESCENTE
- S4 FIN DE COURSE MONTEE
- F1 INTERRUPTEUR THERMIQUE
- X1 CONNECTEUR ALIMENTATEUR AIMANT
- X2 CONNECTEUR MOTEUR
- X3 CONNECTEUR CONDENSATEUR
- X4 BORNIER FREIN
- C1 CONDENSATEUR
- AS ENROULEMENT MOTEUR MONTEE
- AD ENROULEMENT MOTEUR DESCENTE
- AM ENROULEMENT AIMANT FREIN

**SCHALTAFEL (Fig.6)**

- PE SCHUTZLEITER
- L1 PHASENLEITER
- N MITTELLEITER
- S1 NOT-DRUCKSCHALTER
- S2 DRUCKSCHALTER HEBEN
- S3 DRUCKSCHALTER SENKEN
- S4 ENDSCHALTER SENKEN
- F1 WÄRMESCHALTER
- X1 VERBINDER MAGNET-SPEISEGERÄT
- X2 MOTORVERBINDER
- X3 KONDENSATORVERBINDER
- X4 KLEMMBRETT
- C1 KONDENSATOR
- AS MOTORWICKLUNG HUB
- AD MOTORWICKLUNG SENKEN
- AM WICKLUNG BREMSMAGNET

TAB.1			
Lunghezza cavo (m)			
Longueur câble (m)			
Cable length (m)	0 ÷ 15	16 ÷ 25	26 ÷ 45
Kabel Länge (m)			
Longitud cable (m)			
sezione cavo (mm <sup>2</sup> )			
section câble (mm <sup>2</sup> )			
cable (mm <sup>2</sup> )	1.5	2.5	4
kabel (mm <sup>2</sup> )			
cable (mm <sup>2</sup> )			